

1 SECTION  
N.T.S.

2 TYPICAL FOOTING STEP  
N.T.S.

3 SECTION  
N.T.S.

4 SECTION  
1/2"=1'-0"

5 SECTION  
1/2"=1'-0"

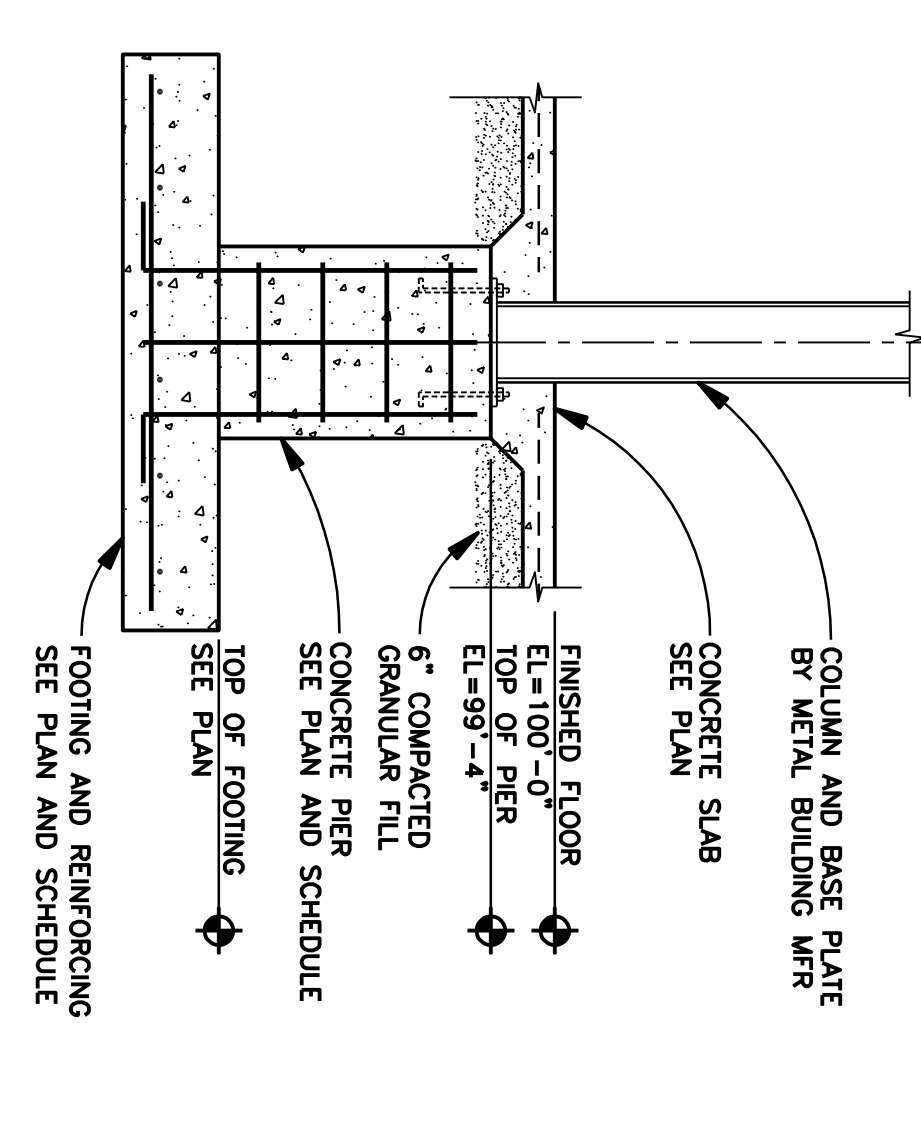
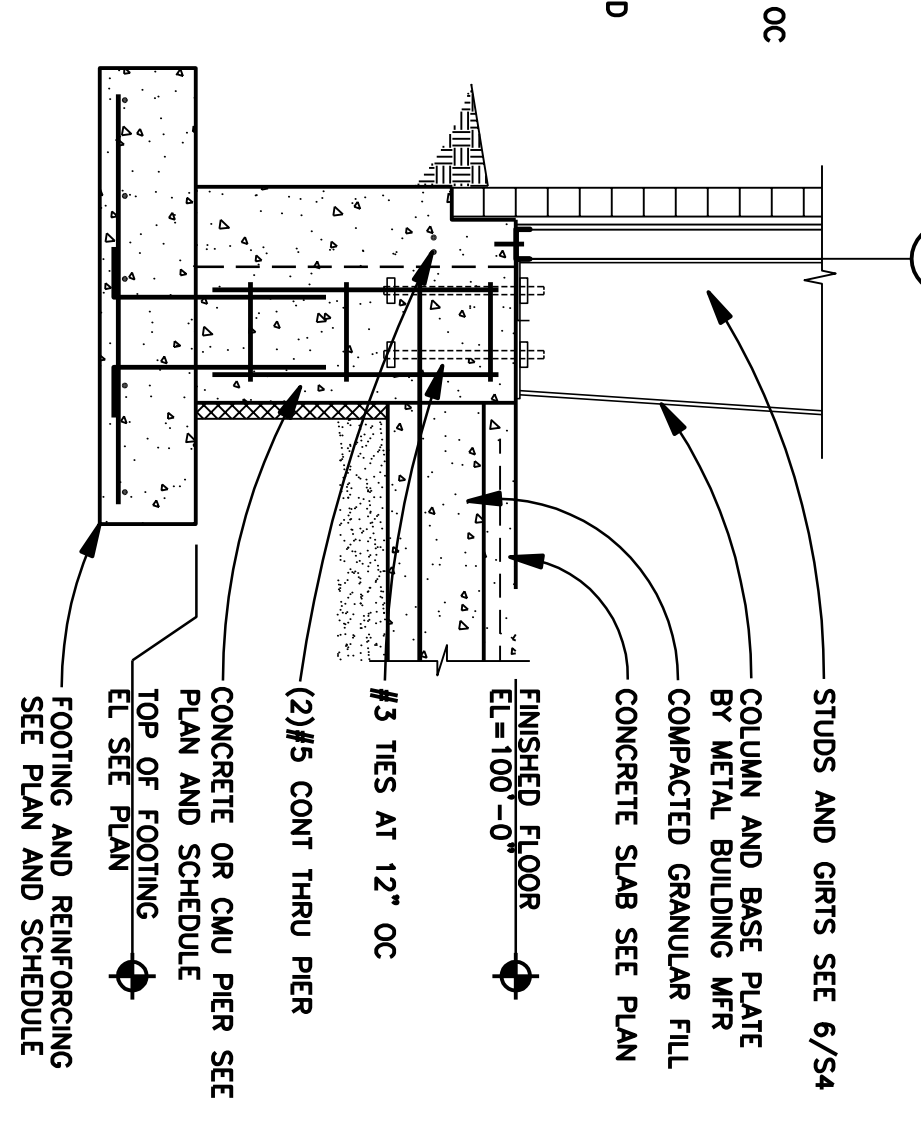
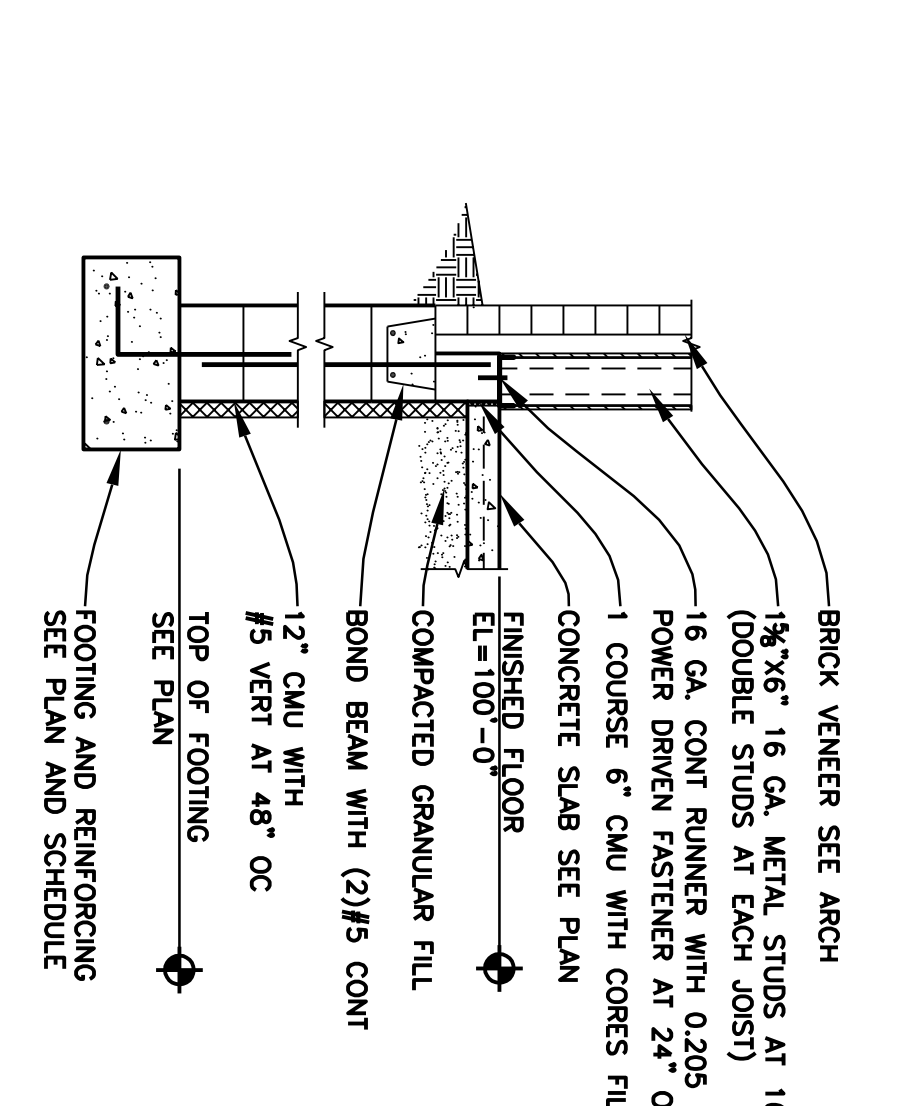
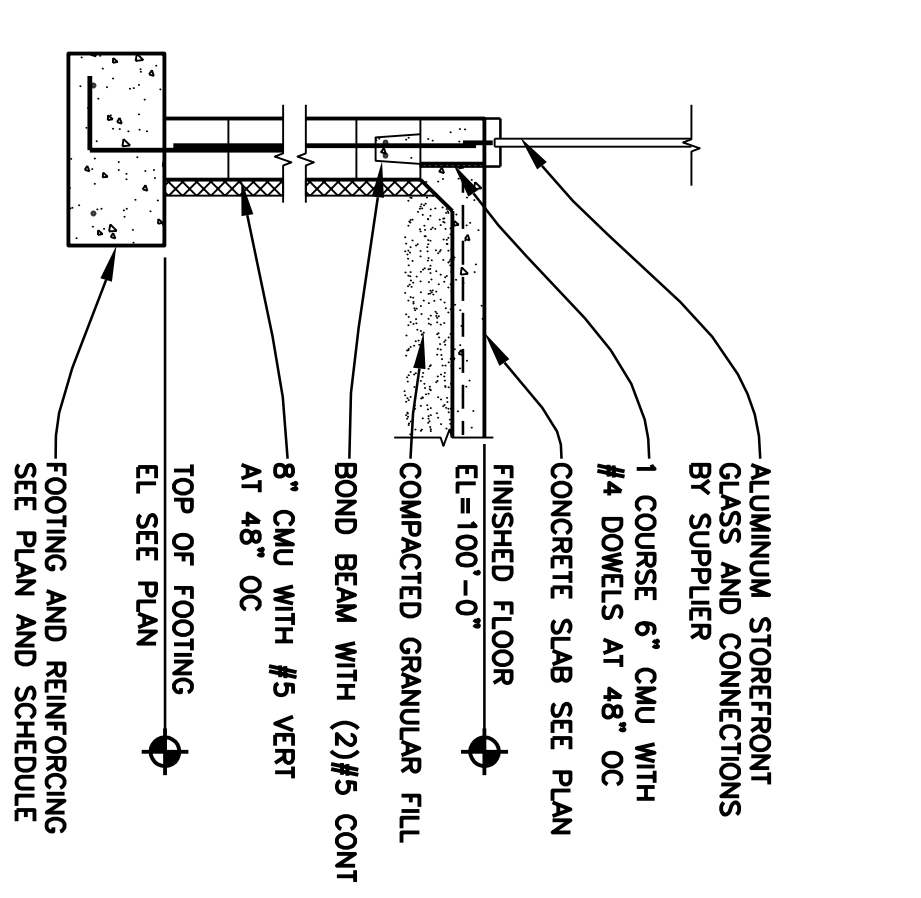
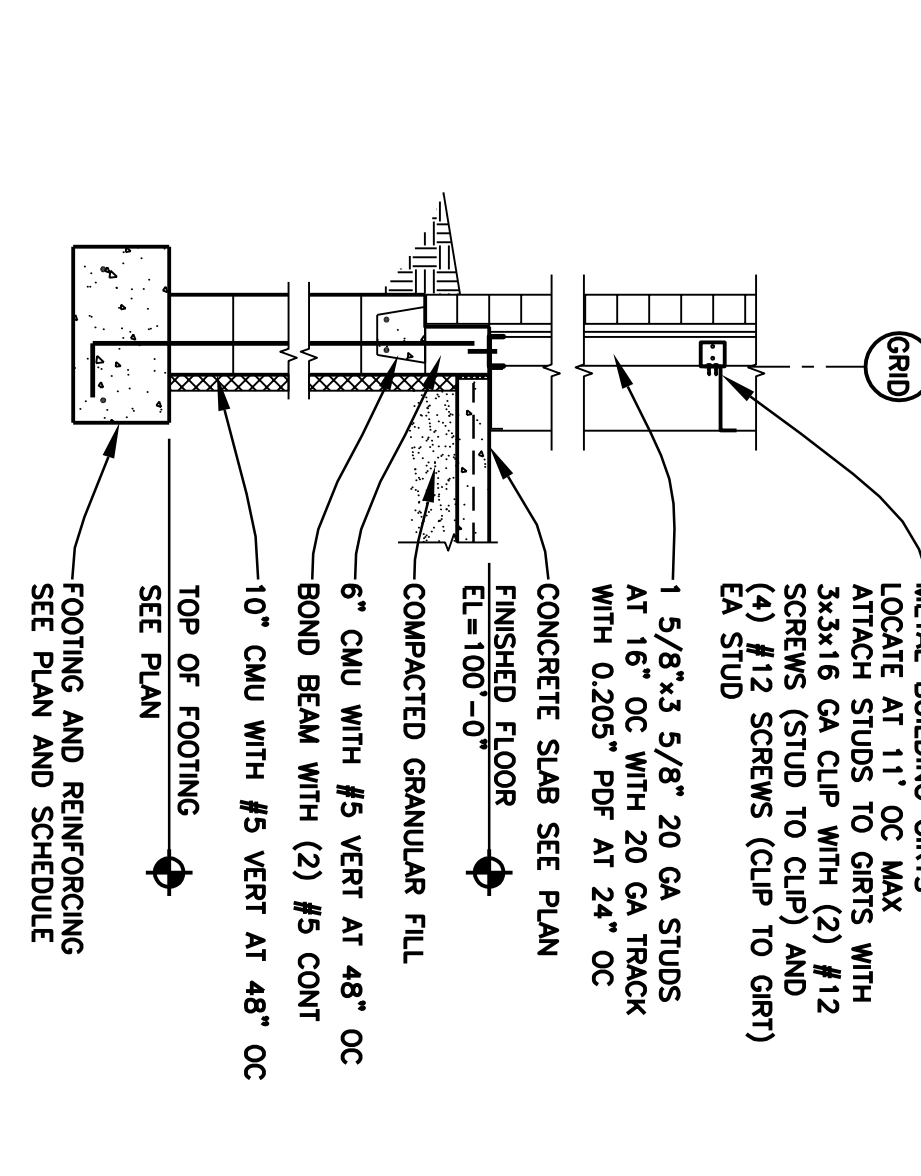

6 SECTION  
1/2"=1'-0"

7 SECTION  
1/2"=1'-0"

8 SECTION  
1/2"=1'-0"

9 SECTION  
1/2"=1'-0"

10 SECTION  
1/2"=1'-0"

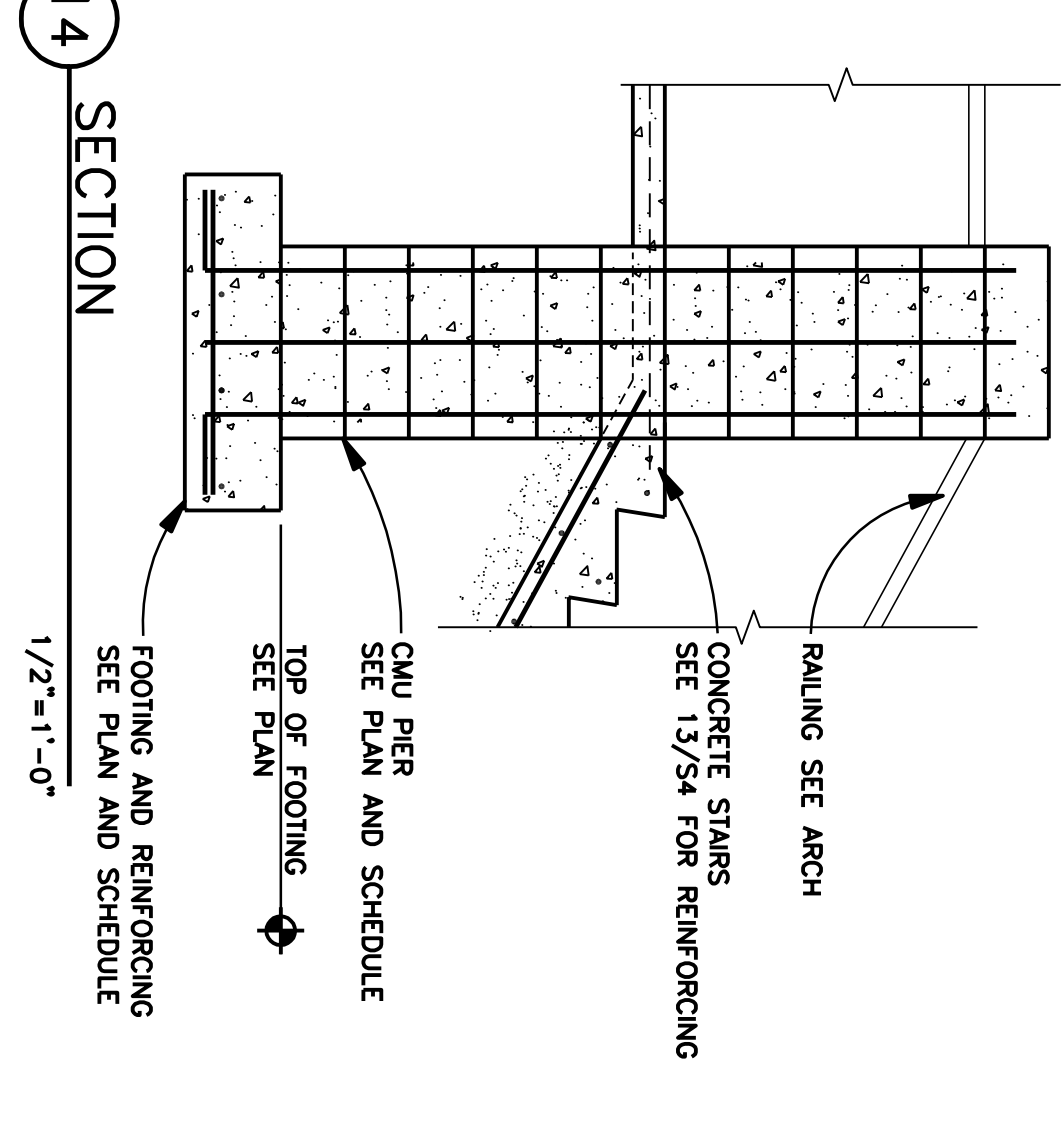
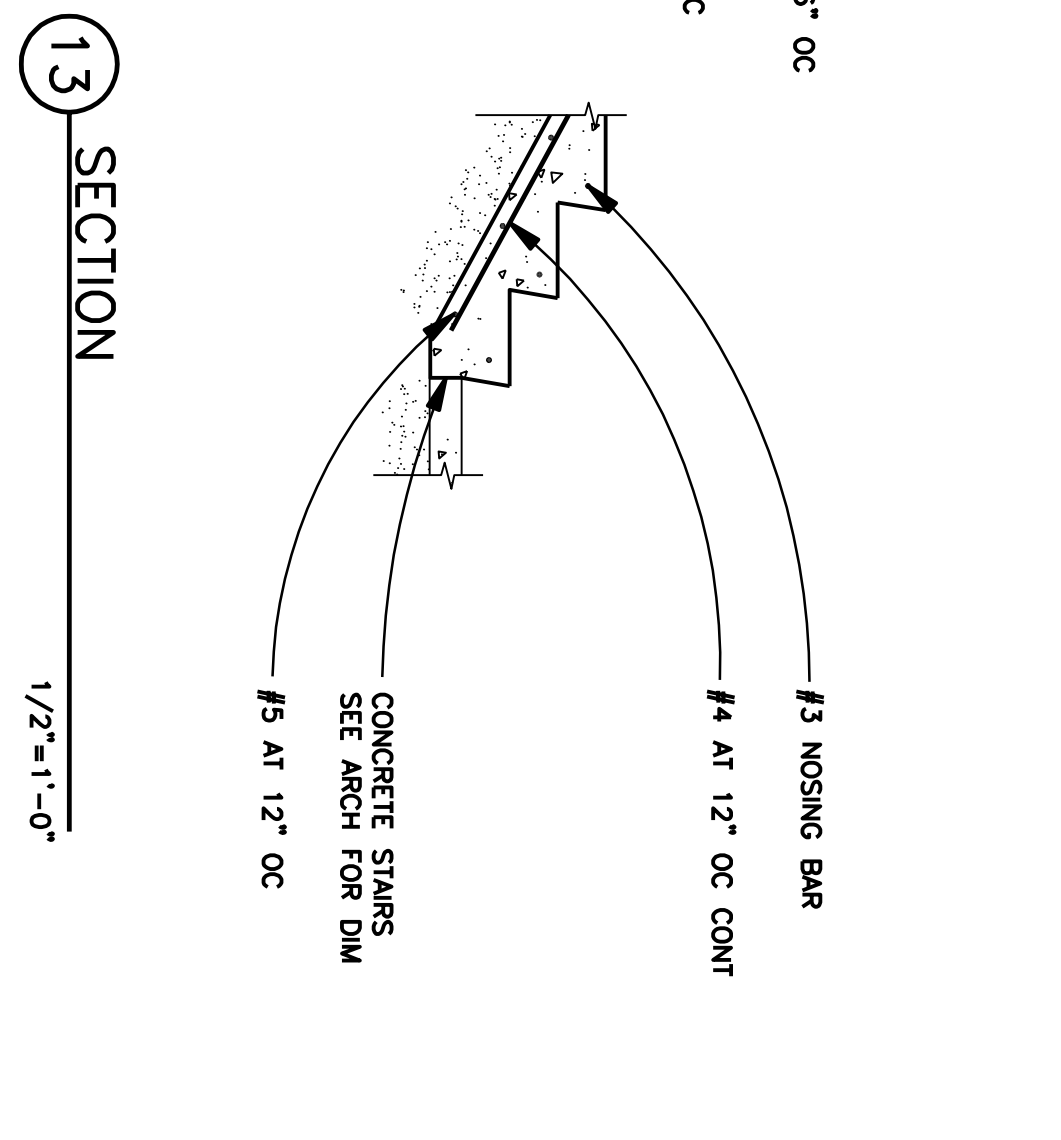
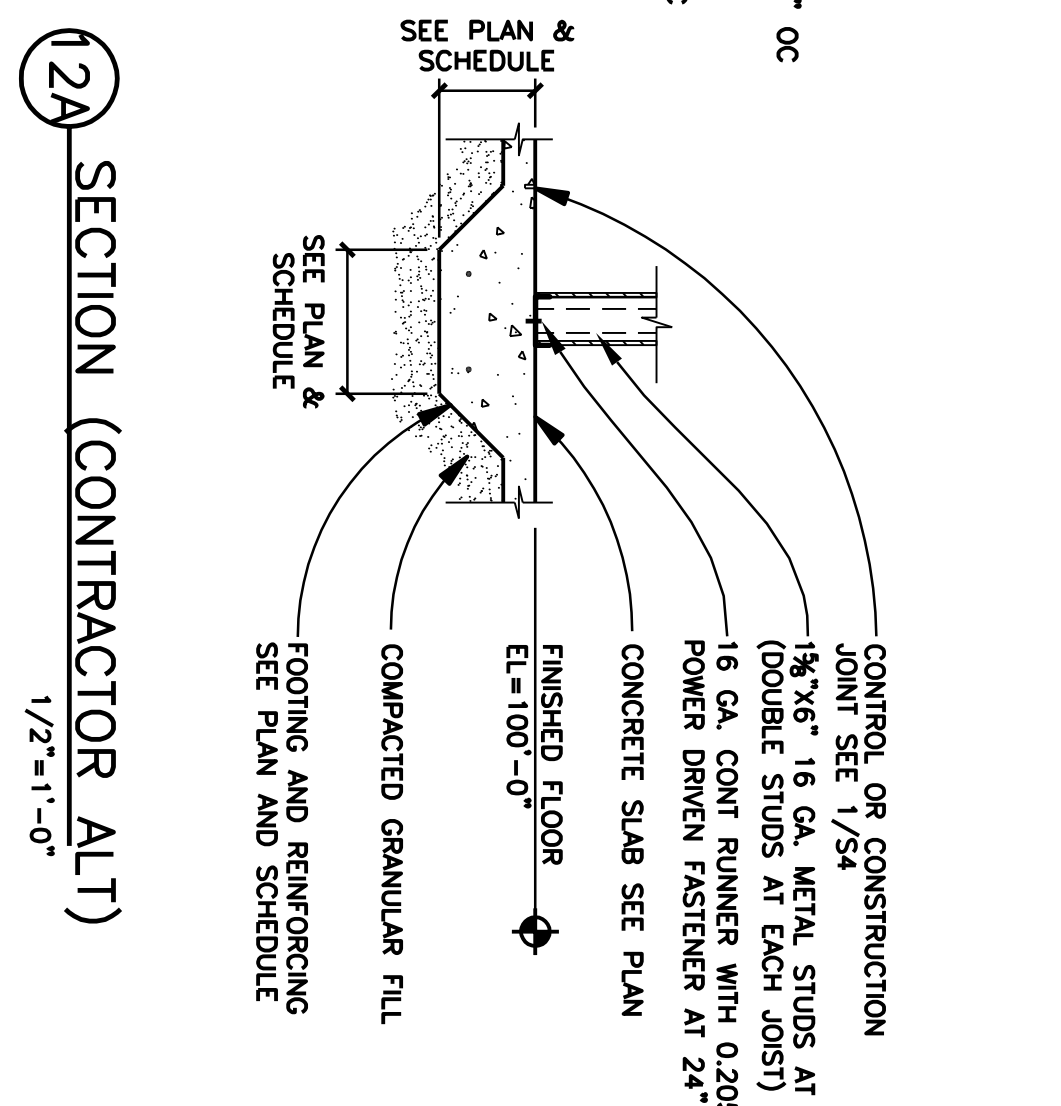
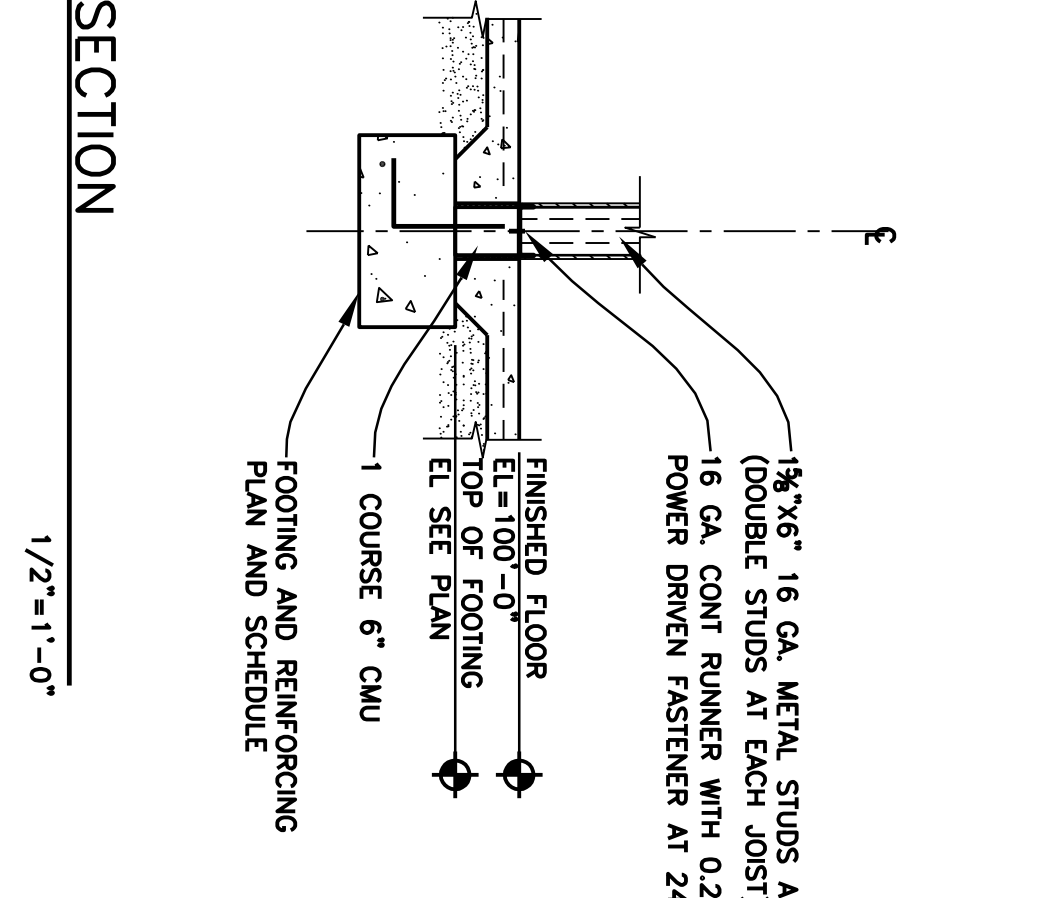
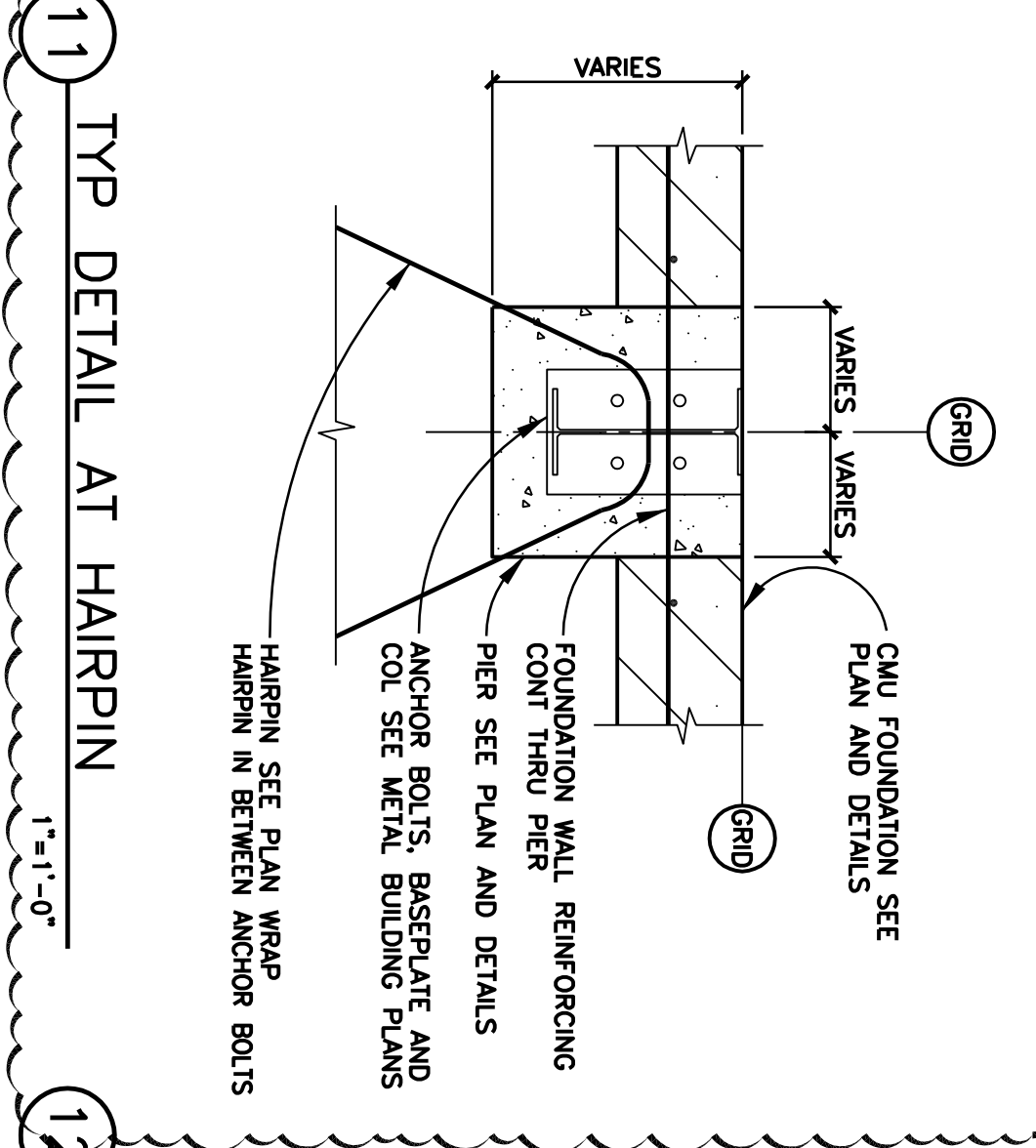

11 TYP DETAIL AT HAIRPIN  
1"=1'-0"

12 SECTION  
1/2"=1'-0"

12A SECTION (CONTRACTOR ALT)  
1/2"=1'-0"

13 SECTION  
1/2"=1'-0"

14 SECTION  
1/2"=1'-0"

SECTIONS AND DETAILS

PROJECT NO.:	06337
SCALE:	1/8"=1'-0"
DATE:	02-13-07
DRAWN BY:	JKD
DRAWN BY:	RS